

Ceramic insulator Bronze with doubleeye M16 – on wire

Order number: 0126.4

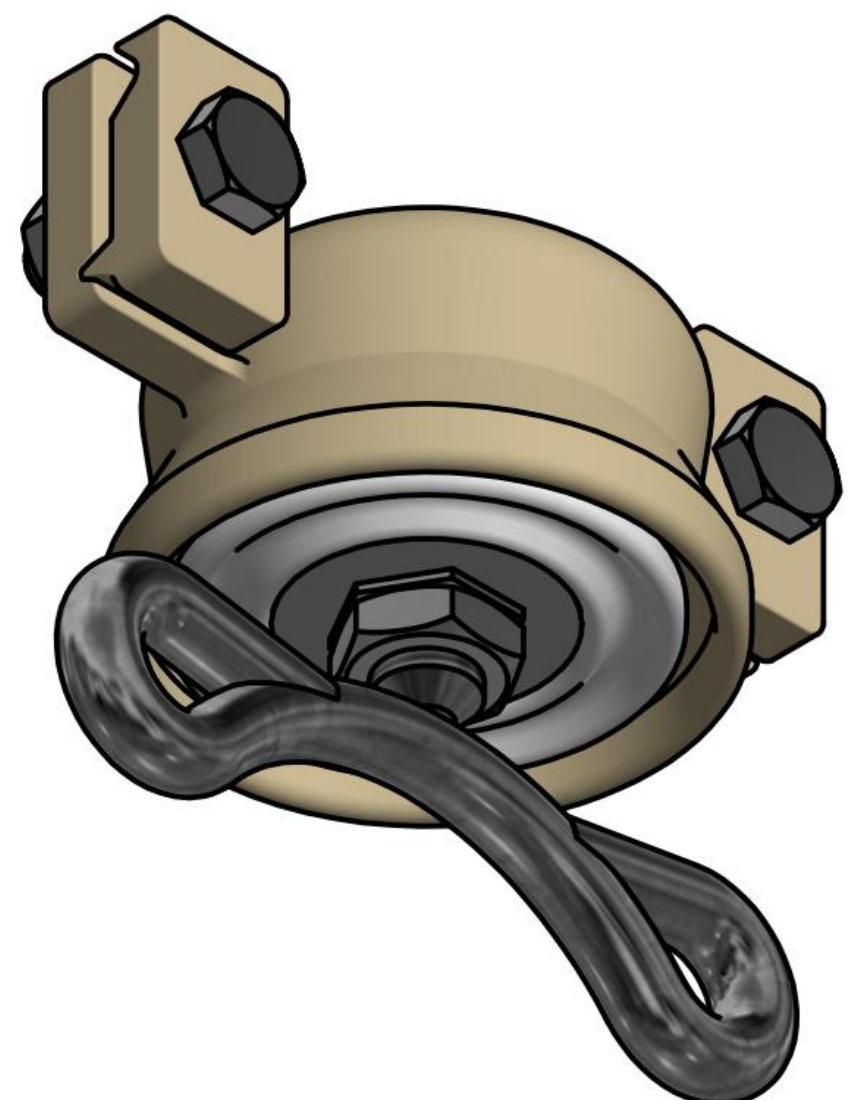
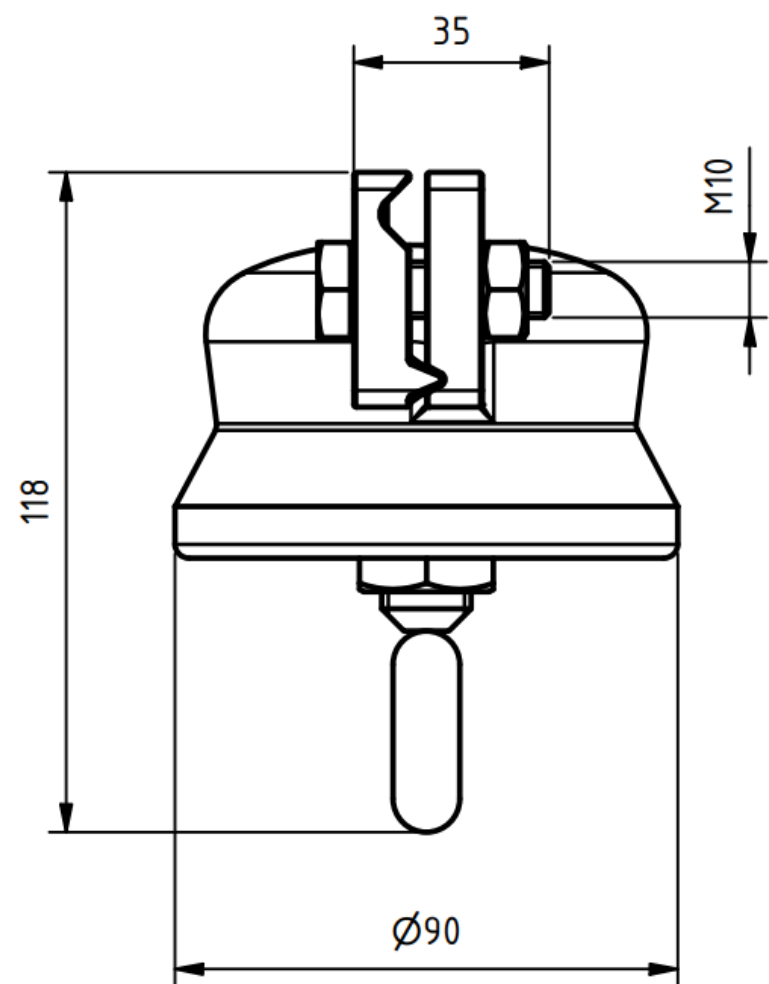
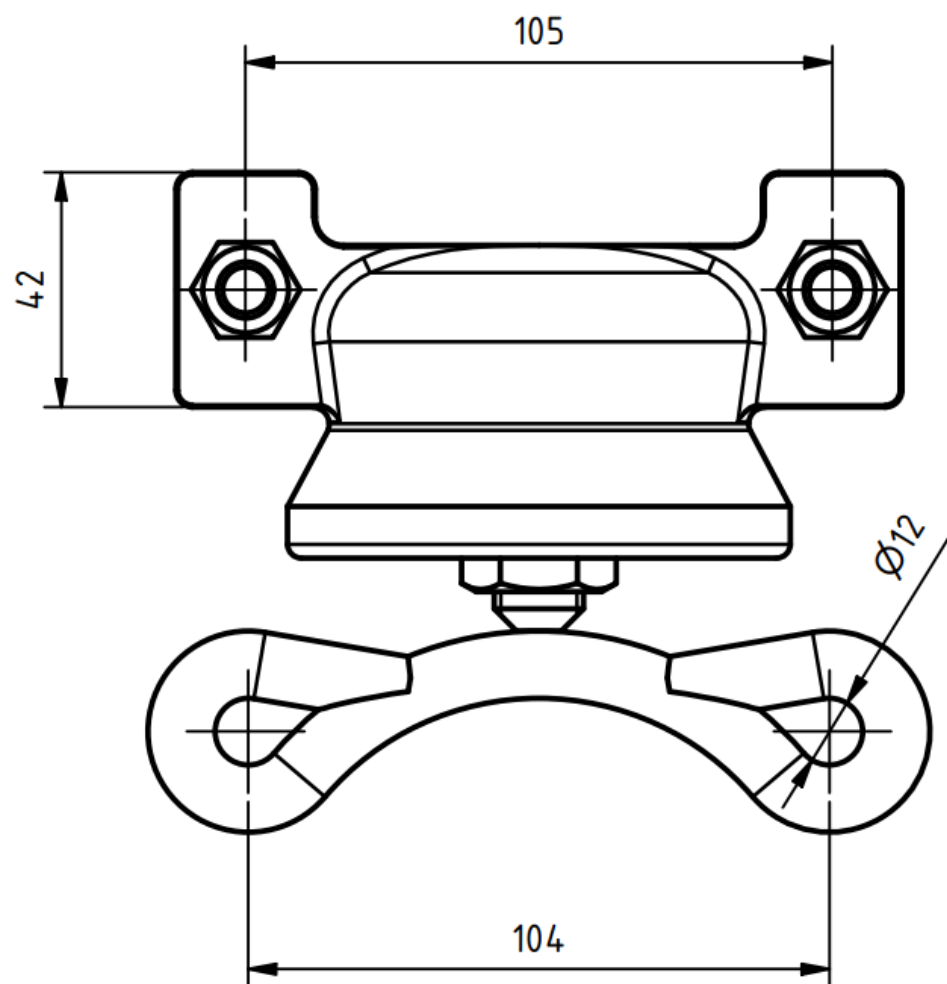

Technical parameters

- Material: Ceramic, Stainless steel, Bronze
- Weight: 1,5 kg (3,3 lb)
- Doubleeye M16 Zn, order no.: 0126.15

Esko spol. s r.o.

Praha 5, Jinonická 80, 15800 CZ
IČO: 60471999
DIČ: CZ60471999

Email: info@esko-praha.cz
Phone: +420257290280
www.esko-praha.cz